

RoHS



本體		螺帽
材質	處理	材質
S45C	無電解鍍	SUS304

WAT-SBRH

WAT-SBFH

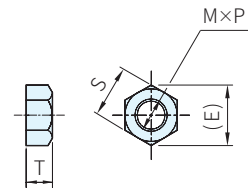
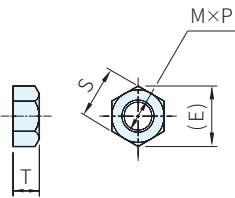
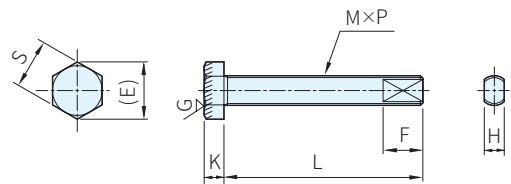
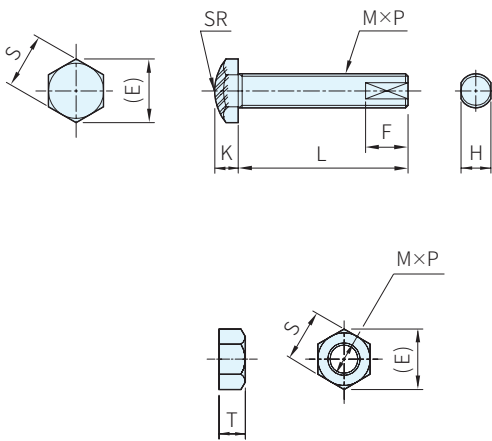

品號	M×P	L	K	S	(E)	SR	F	H	T	備註	庫存
WAT-SBRH6-40M	M6×0.75	40	4.0	10	11.5	10	8	4.0	5.0	斜線部淬火 HRC35以上 拋光研磨	△
WAT-SBRH6-50M		50									△
WAT-SBRH6-60M		60									△
WAT-SBRH8-40M	M8×1	40	5.5	13	15.0	12	10	5.5	6.5		△
WAT-SBRH8-50M		50									△
WAT-SBRH8-60M		60									△

品號	M×P	L	K	S	(E)	F	H	T	備註	庫存
WAT-SBFH6-40M	M6×0.75	40	4.0	10	11.5	8	4.0	5.0	斜線部淬火 HRC35以上 研磨	△
WAT-SBFH6-50M		50								△
WAT-SBFH6-60M		60								△
WAT-SBFH8-40M	M8×1	40	5.5	13	15.0	10	5.5	6.5		△
WAT-SBFH8-50M		50								△
WAT-SBFH8-60M		60								△

Ps. 備註

· 螺絲頭部淬火處理

訂貨： 交期： 天

WAT-SBRH6-40M